

SOPHOS

Operating Instructions

APX 120



Foreword

We are pleased to welcome you as a new Sophos APX Series customer.

Sophos APX Series access points are high performance wireless products using the latest 802.11ac Wave 2 technology for a best-in-class user experience. The APX Series models can be easily managed in Sophos Central, our cloud-based security management platform. All you need to do is set up a Sophos Central account and plug in the device anywhere in your network. The access point will find the cloud-based controller automatically and become operable within seconds.

These operating instructions will help you setup your Sophos Central account, install and configure your Sophos APX Series access point and also provide detailed technical specifications. In addition, please also see the following documents that contain useful information on safety, regulatory compliance, and configuration options:

- Sophos APX Series Safety Instructions and Regulatory Information
- Sophos APX Series Quick Start Guide

The instructions must be read carefully prior to using the device and should be kept in a safe place. You can download all user manuals and additional documentation from the Sophos Knowledgebase under www.sophos.com/en-us/support/knowledgebase.aspx or from www.sophos.com/get-started-ap.



Security Symbols

The following symbol and its meaning appears in the Quick Start Guide, Safety Instructions and in these Operating Instructions.

Caution and Important Note. If these notes are not correctly observed:

- This is dangerous to life and the environment
- The access point may be damaged
- The functions of the access point will be no longer guaranteed
- Sophos shall not be liable for damages arising from a failure to comply with the Safety Instructions

Designed Use

The access point must be installed pursuant to the current installation notes. Otherwise failure-free and safe operation cannot be guaranteed. The EU declaration of conformity is available upon request from the following address:

Sophos Technology GmbH
Gustav-Stresemann-Ring 1
65189 Wiesbaden
Germany

Operating Elements and Connections

APX 120

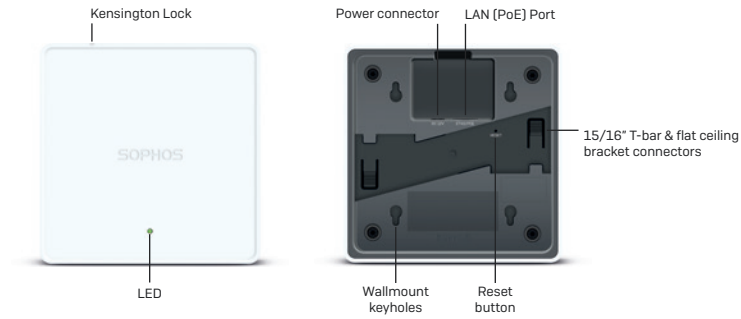

Component Descriptions

Component	Description
Status LED	The Status LED indicates the operational state of your access point such as boot status, firmware updates and error states. For details, see table "LED Status" below.
Eth0 (PoE)	Eth0 is the Ethernet port to connect your access point to your network. This port can also be connected to a PoE capable source (PoE Injector or PoE switch) to power your access point. Alternatively, you can power the access point using an APX 120 Power Supply (available as an accessory from your Sophos partner).
Power Connector	If you are not using PoE as a power source you can connect an optionally available APX 120 Power supply here.
Reset button	The reset button allows you to reboot the device and reset its configuration to the factory default. For details, please see section "Reboot & Reset"
Kensington Lock	You can physically secure the AP by attaching a lock and cable (such as a Kensington® notebook lock) to the device lock slot.

LED Status

LED on Front		
Off	Off	AP is off or reboot started.
Green	Solid	Normal operation.
	Flashing	AP is booting & connecting to wireless controller or applying configuration*.
Amber	Solid	AP has no connection
	Flashing	AP is not claimed by wireless controller
Red	Solid	Error, no wireless controller found. AP will reboot (if not yet claimed by a controller). Check network connection if error persists. If reset button pressed: AP preparing configuration reset
	Flashing slowly	Configuration reset in progress*
	Flashing fast	Firmware update in progress

* Your AP should recover from this state after a maximum of 5 minutes.

Connection and Configuration

The initial connection of your access point to your network and the wireless controller is described in the APX Quick Start Guide which was shipped with your device or is available under www.sophos.com/get-started-ap.

For the access point to communicate with Sophos Central servers the following ports will need to be open on your firewall:

- 443 [HTTPS]
- 80 [HTTP]
- 123 [NTP]

After successful connection you can start your initial configuration.

Setting up your access point in Sophos Central

You will need a Sophos Central account to manage your access points. Please go to <https://central.sophos.com> to sign in under your account or create a new account.

After signing in select *Wireless* from the popup screen or click on *Wireless* in the left navigation to get started.

Follow the Onboarding Wizard to register your access point.

For more information, please see the [Sophos Central Admin Help](#).

Reboot & Reset

Your access point can be rebooted with the installed configuration or reset to the factory default configuration depending on how long you press and hold the reset button.

Reboot with current image and configuration

1. Press reset button
2. Release reset button
3. AP reboots (LED will go off, then will turn to solid green)

Reboot with current image and clear configuration

1. Press and hold reset button
2. AP reboots (LED will go off and then switch to green briefly)
3. LED will turn solid red for 5 sec. You can still cancel the configuration clearance process by releasing the reset button before the LED starts blinking
4. LED will blink red (configuration will be cleared)
5. Release reset button
6. AP reboots with factory default settings

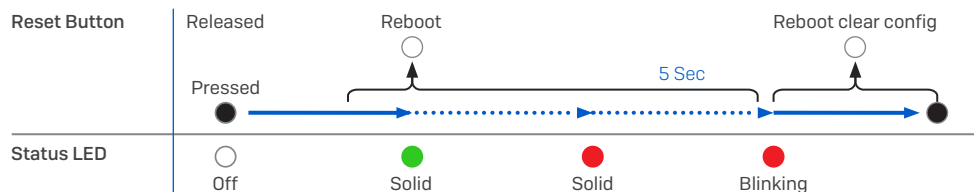

Technical specifications

APX 120	
Environment	
Power consumption	11.8 W (max.)
Power over Ethernet (PoE) requirements	802.3af
DC Power Supply	12V/1A
Operating temperature	0°-40° C
Storage temperature	-40°-80° C
Humidity	10-95% non-condensing
Hazardous substances	RoHS-2 and REACH compliant
Physical specification	
I/O ports	1x RJ45 10/100/1000 Ethernet w/PoE (802.3af) 1x Reset button 1x Kensington security slot
Memory	256 MByte DDR3 256 Mbyte NAND Flash 2 Mbyte SPI NOR Flash
Mounting	Desktop Wall-mount hang Ceiling (15/16 T-bar, flat ceiling)
Dimensions (Width x Depth x Height)	144x144x33.5 mm
Weight	256g
Wireless specification	
Radios	1x 2.4 GHz single band 1x 5 GHz single band
Antennas	2x internal dual band antennas Antenna peak gain: 3.7 dBi at 2.4 GHz / 4.2 dBi at 5 GHz
MIMO capabilities	2x2 MIMO at 2.4 GHz, and 2x2 MU-MIMO (802.11ac Wave 2) at 5 GHz
Supported WLAN standards	IEEE 802.11 a/b/g/n/ac
SSIDs	8 per radio, 16 in total
Max. throughput	867Mbps (5 G) + 300Mbps (2.4 G)

Performance			
Band/Mode	Data Rate	TX Power Maximum EIRP [dBm]	RX Sensitivity [dBm]
2.412–2.472 GHz (11b)	1 Mbps	22	-98
	2 Mbps	22	-95
	5.5 Mbps	23	-93
	11 Mbps	23	-90
2.412–2.472 GHz (11g)	6 Mbps	23	-92
	9 Mbps	23	-91
	12 Mbps	23	-90
	18 Mbps	23	-88
	24 Mbps	23	-85
	36 Mbps	22	-82
	48 Mbps	21	-77
	54 Mbps	20	-76
2.412–2.472 GHz (11n HT20)	MCS 0	23	-92
	MCS 1	22	-90
	MCS 2	22	-88
	MCS 3	22	-85
	MCS 4	22	-82
	MCS 5	22	-78
	MCS 6	22	-76
	MCS 7	21	-75
5.180–5.825 GHz (11a)	6 Mbps	23	-91
	9 Mbps	23	-90
	12 Mbps	23	-89
	18 Mbps	23	-87
	24 Mbps	23	-84
	36 Mbps	23	-81
	48 Mbps	22	-76
	54 Mbps	22	-75
5.180–5.825 GHz (11ac VHT20)	MCS0	23	-91
	MCS1	23	-88
	MCS2	23	-87
	MCS3	23	-83
	MCS4	23	-81
	MCS5	23	-76
	MCS6	22	-75
	MCS7	22	-73
5.180–5.825 GHz (11ac VHT40)	MCS0	23	-88
	MCS1	23	-86
	MCS2	23	-84
	MCS3	23	-81
	MCS4	22	-76
	MCS5	22	-74
	MCS6	21	-72
	MCS7	21	-70
	MCS8	20	-66
5.180–5.825 GHz (11ac VHT80)	MCS0	23	-84
	MCS1	23	-83
	MCS2	23	-81
	MCS3	23	-77
	MCS4	21	-75
	MCS5	21	-71
	MCS6	21	-69
	MCS7	21	-68
	MCS8	19	-64
MCS9	19	-61	

Radiation patterns

2.4 G Band

H-plane

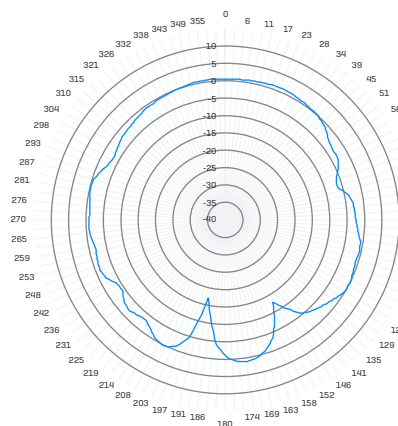

V-plane

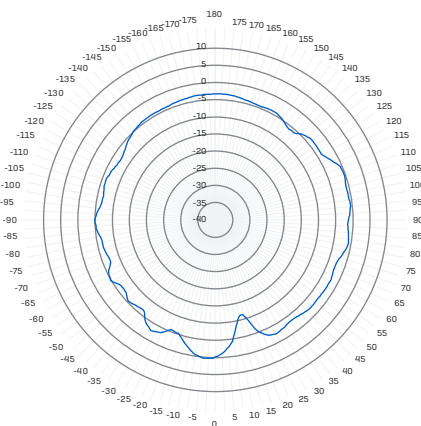

5 G Band

H-plane

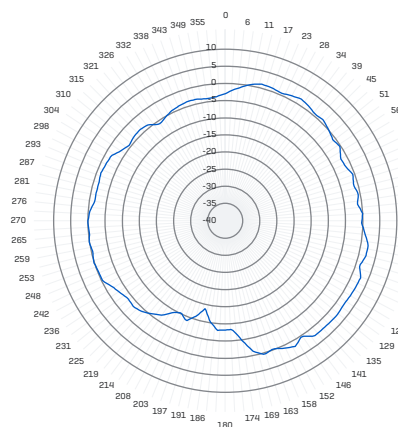

V-plane

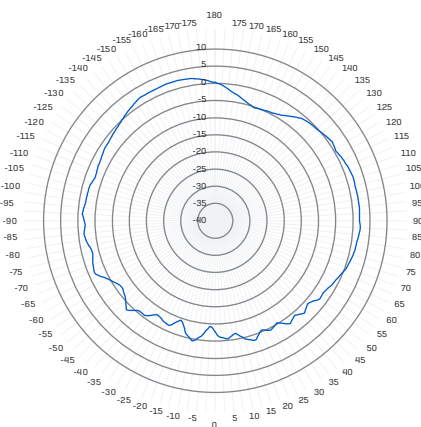

Mounting instructions

There are various mounting options available allowing you to hang your access point on the wall or mount it to various ceiling types. The following sections provide detailed instructions for the various options which are available today.

Your APX 120 supports the following mounting options:

- Wall mount hang
- Ceiling mount for 15/16" ceiling track, flush ceiling tiles
- Flat ceiling mount (by using the supplied mounting bracket)

APX 120 Mounting template

Do not shrink to fit when printing

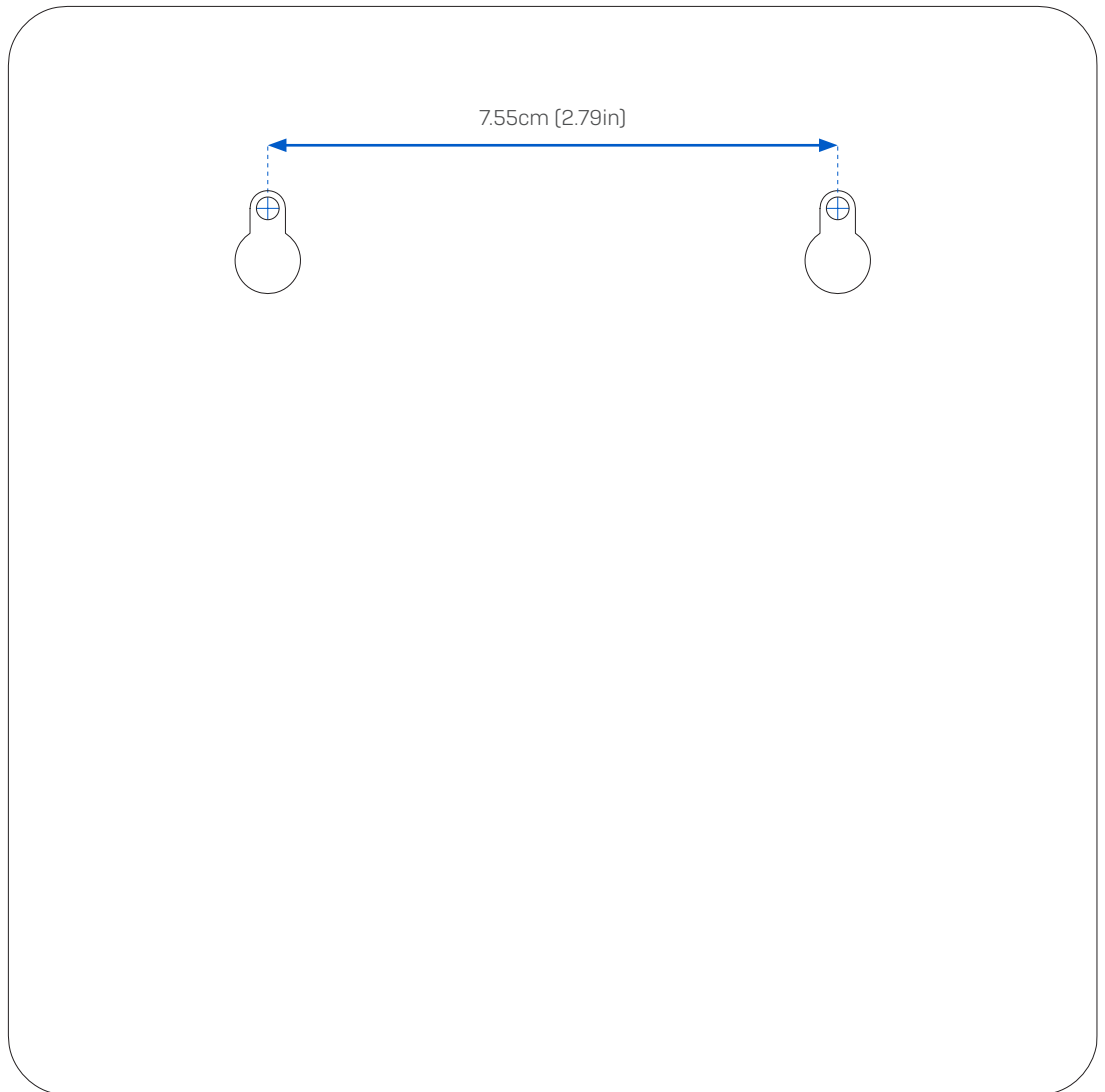

Wall mount

You can either hang the unit on the wall by using the wall mount keyholes on the rear of the unit or by using the supplied mounting bracket.

The following procedure explains how to use the keyholes. The use of the mounting bracket is described within the section "flat ceiling mount".

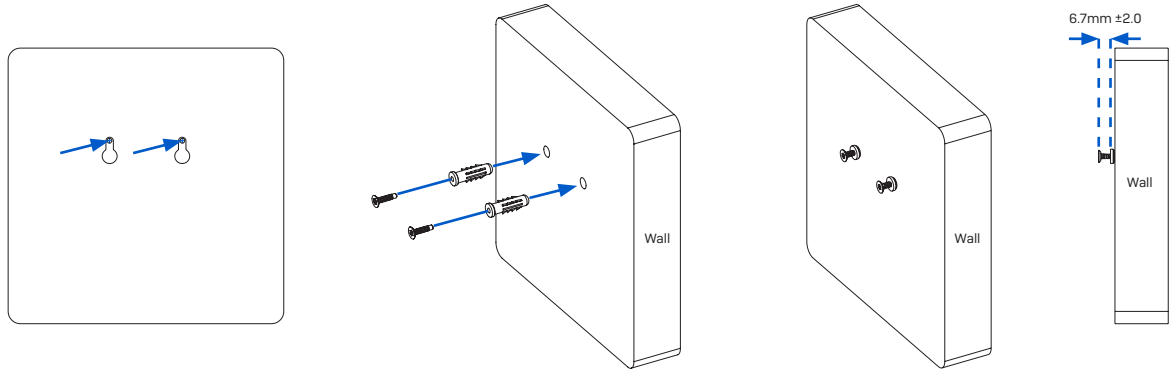

Mounting instructions

1. Use the wall mount template to mark the screw mounting positions on the wall.
2. Drill the 2 supplied wall anchors into the wall at the marked positions and screw the 2 supplied screws into them. Make sure they stand out ~6.7mm.
3. Hang the access point on the wall by aligning the key holes with the mounted screws.

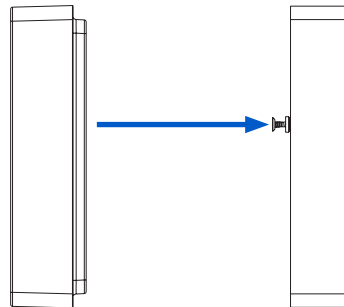

Ceiling mount for 15/16" ceiling track, flush ceiling tiles

You can directly attach your APX 120 to a 15/16" ceiling track by using the integrated connectors on the rear of the unit.

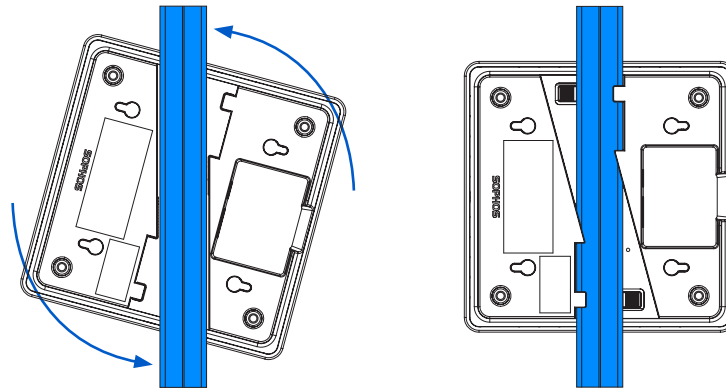

Mounting instructions

1. To install, put the access point underneath the ceiling rail and turn it into place.
2. To dismount, push down the spring locks and turn the access point in the other direction.

Flat ceiling mount

For flat ceiling mount please use the supplied mounting bracket. This can also be used as an alternative method for wall mount hang.

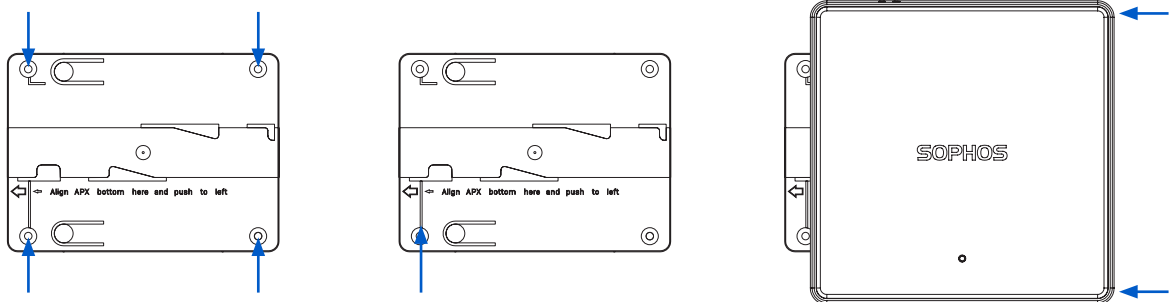

Mounting instructions

1. Use the main bracket as a template to mark the screw mounting positions on the wall.
2. Mount the bracket on the wall or ceiling by using the four dowel and screws within the scope of supply.
3. Find the marking line on the bracket.
4. Place the access point above the bracket and align the left-hand side of the access point with the marking on the bracket.
5. Slightly push the access point and gently slide it to the left until it snaps into place.
6. To unmount, gently slide the access point to the right.

United Kingdom and Worldwide Sales
Tel: +44 (0)8447 671131
Email: sales@sophos.com

North American Sales
Toll Free: 1-866-866-2802
Email: nasales@sophos.com

Australia and New Zealand Sales
Tel: +61 2 9409 9100
Email: sales@sophos.com.au

Asia Sales
Tel: +65 62244168
Email: salesasia@sophos.com